

INSTRUCTION MANUAL

AM Brushless motors & BL drives



THANK YOU VERY MUCH FOR YOUR PURCHASE
OF ADLEE PRODUCTS.
PLEASE READ THIS INSTRUCTION MANUAL
BEFORE INSTALLATION.

CONTENTS

1. PREFACE	1
2. RECEIVING	4
3. ENVIRONMENTAL REQUESTS	5
4. SPECIFICATION	7
5. DIMENSIONS	9
6. DIGITAL OPERATION PANEL	15
7. TERMINALS AND WIRING	16
8. OPERATION AND CONNECTION	22
9. TROUBLE SHOOTING	61
Appendix	62

1. Preface

Thank you for purchasing ADLEEPOWER AM Brushless DC motor and BL drives. Please read this manual thoroughly before installation and operation.

This manual should be stored by the user for maintenance reference and inspection.



Danger

Indicated a potentially hazardous situation which, if not avoided, could result in death or serious personnel injury.

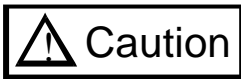

Caution

Indicates a potentially hazardous situation which, if not avoided, may result in minor or moderate personnel injury and damage to equipment.



Danger

- Only commence wiring after verifying that the power supply is turned OFF.
- Wiring should be performed only by qualified personnel.
- Make sure to connect the ground terminal.  Ground resistance 0.1 or less.
- Do not measure any element signal during operation. Failure to observe this caution can result in personal injury.
- Perform maintenance or inspection only after verifying that the CHARGE LED goes OFF 5 minute and after the main circuit power source is turned OFF.
- Never modify the product. Failure to observe this warning can result in an electrical shock or personal injury and will invalidate the guarantee.



Caution

- Mount the driver on nonflammable material.(i.e. metal)
- When mounting units in an enclosure, install a fan or other cooling device to keep the intake air temperature below 45 .
- Overheating may cause a fire or damage to the unit.



Caution

- Please confirm power source voltage to driver input rated voltage.
- Please make sure the wiring is correct when driver adds a braking resistor.
- Do not put the advance phase capacitor between the driver and motor.
-  is grounding symbols. Be sure ground both the driver and motor.
- Check the power connector is locked on the terminal of driver.
(Do not looseness, otherwise, connector will be oxidized and over heat.)
- Check that the input power source voltage is correct.
- Be sure to connect the power source to L1,L2(input terminals) and the motor to U.V.W.(output terminals). (Wrong connection will damage the driver.)

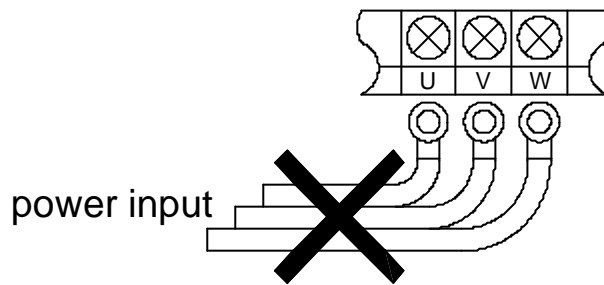

- Do not make any replacement for electronic parts when troubles are occurred.
- Do not perform a withstand voltage test of the driver. It may cause semiconductor parts or power switches to be damage.
- Do not install relay between power source and driver for operating start and stop.

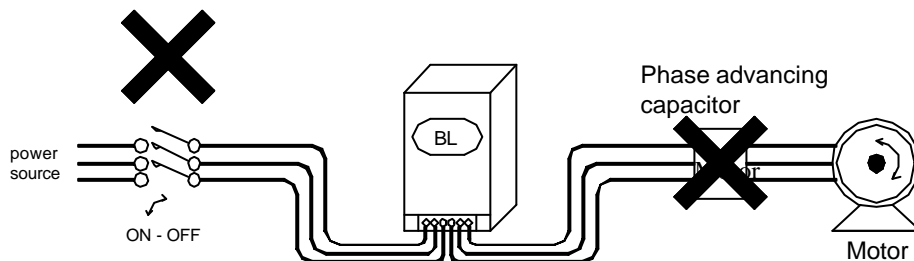



Caution

- For operating motor "start" and "stop" should use keypad or terminal to control these functions.

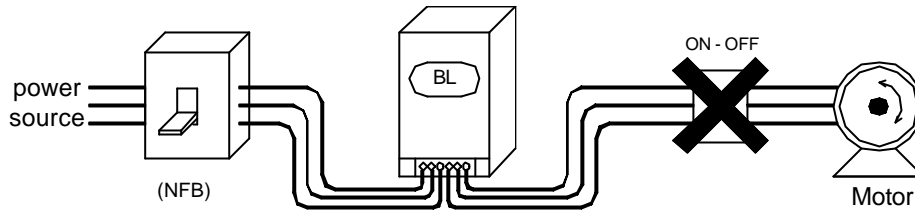

- Do not install phase advancing capacitor between driver and motor for operating motor.

2. Receiving

2-1 Acceptance Inspection and Precautions

During product manufacturing, packaging, and shipment have been standardised. If any problem is discovered, please contact your dealer or producer immediately.

- Any damage with each product after shipping.
- The instruction manual is contained in the package.
- The product as same as an order (check the nameplate, voltage and frequency).
- All of terminals are locked and unusual substance.
- The keyboard of remote control must be corrected.
- Check the additional accessories.

2-2 Nameplate

Motor

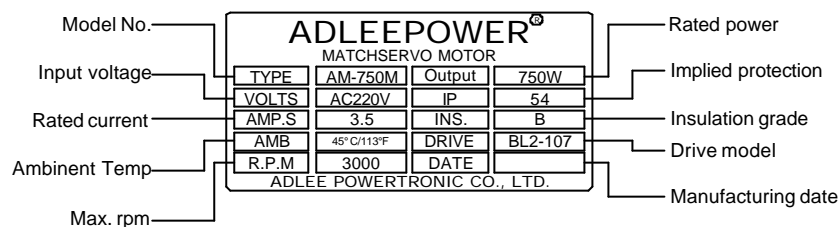

Drive

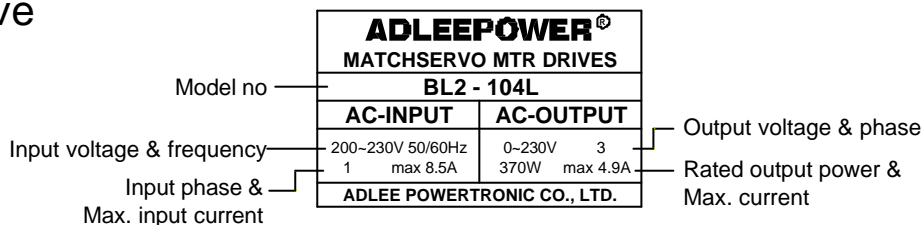

Motor

AM - XXX L (B)

① ② ③

Drive

BL X - X XX X

④ ⑤ ⑥ ⑦

① : Rated power : example 370 represent 370W

② : Rated speed : L : 2000RPM M : 3000RPM
H/HX : 6000RPM

③ : With B : with magnet brake

④ : Rated voltage : 2 : 220V 4 : 440V

⑤ : 1 : single phase input 3 : three phase input

⑥ : 01 : 0.1KW 02 : 0.2KW 04 : 0.4KW
07 : 0.75KW 15 : 1.5KW 22 : 2.2KW

3. Environmental requests

Operation

Air temperature	-10~45 (14~113)
Air pressure	86~106kPa
Attitude	Under 1000 meters
Vibration	Less than 20HZ : maximum 9.86m/s ² 20~50HZ : maximum 5.88m/s ²

Storage

Air temperature	-20~60 (-4~140)
Air pressure	86~106kPa
Humidity	Less than 90%, no frosting

Transportation

Air temperature	-20~60 (-4~140)
Air pressure	86~106kPa
Humidity	Less than 90%, no frosting
Vibration	Less than 20HZ : maximum 9.86m/s ² 20~50HZ : maximum 5.88m/s ²

Note :

- a. Bad installation can reduce product service life.
- b. Do not put motors and drives into worse environment. Such as high temperature/humidity/vibration, corrosiveness gas, burst.
- c. Keep enough cooling space for motors and drives.

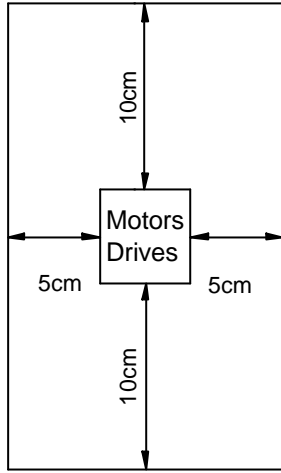

4. Specification

Rated Power	W	60	90	120	180	250	370
Motor No.		AM-60 L/M	AM-90 L/M/H	AM-120 L/M/H	AM-180 L/M/H	AM-250 L/M/H	AM-370 L/M/H
Drive No.		BL2-101	BL2-101	BL2-102	BL2-102	BL2-104	BL2-104
Input Voltage		220V \pm 10% 1					
Input Frequency	HZ	50 / 60					
Max. input current		3.5	3.8	5.5	5.8	10.8	11
Motor Phase		3					
Rated Torque	Kg-cm (in-lb)	2.9/2.0 (2.5/1.7)	4.4/2.9/1.5 (3.8/2.5/1.3)	5.8/3.9/2.0 (5.0/3.4/1.7)	8.8/5.8/2.9 (7.6/5.0/2.5)	12.0/8.1/4.0 (10.4/7.0/3.5)	18.0/12.0/6.0 (15.6/10.4/5.2)
Rated Speed	RPM	L/M/H : 2000 / 3000 / 6000					
Max. Efficiency	%	> 80	> 80	> 80	> 80	> 80	> 80
Max. Output	W	210	270	360	450	750	900
Max. Torque	Kg-cm (in-lb)	10.5/7.0 (9.1/6.1)	13.2/8.7/4.5 (11.4/7.5/3.9)	21.0/14.0/7.0 (18.2/12.1/6.1)	26.4/17.4/8.7 (22.9/15.1/7.5)	45.0/30.0/15.0 (39.0/26.0/13.0)	54.0/36.0/18.0 (46.8/31.2/15.6)
Variable Speed Range	RPM	L : 0~2000 M : 0~3000 H : 0~6000					
Acc. Dec. Time		0.1 ~ 600.0 Sec					
Speed regulation	Load	\pm 1% Below (0~Rated Torque at rated speed)					
	Voltage	\pm 1% Below (Source voltage \pm 10% at rated speed No Load)					
	Temperature	\pm 1% Below (-10~45 / 14~113 at rated speed No Load)					
Motor Insulation/ Max. Working TEMP.		B Class (130 /266) / Max. 100 /212					
Type of control		Rectangular wave PWM					
Speed command		1. Built-in potentiometer 2. External Potentiometer 2 k 3. 0~5VDC, 0~10VDC, 4~20mA control 4.RS485					
Operation		1. Pannel : CW、CCW、Key 2. Terminal : Type of input : Photocoupler, input impedance 2.2 k / CW、CCW、Common (4.5 ~ 5VDC) 3. Communication : RS485					
Output signal		Open collect output, External use condition DC5V、10mA below SPEED OUT、 Fault relay A/B					
Protection		Any phenomenons as below will come to stop output alarm signal will be output and the motor. ● Over load : Motor working temperature is not over 100 (212). ● Over heat : Power modular over heat shut down itself. ● Lost phase : Motor signals are abnormal, due to motor cables was broken or disconnector. ● Phase to phase short circuit.					
Motor enclosure type		IP40					
Figure No.		1	1	2	3	4	5 4(M/H)
Motor Weight	Kg (lb)	2.1/2.1 (1.8/1.8)	2.4/2.4/2.4 (2.1/2.1/2.1)	2.6/2.5/2.5 (2.3/2.2/2.2)	2.9/2.7/2.7 (2.5/2.3/2.3)	4.0/3.8/3.7 (3.5/3.3/3.2)	4.5/4.0/4.0 (3.9/3.5/3.5)
BL Driver Weight	Kg (lb)	1.1 (1.0)	1.1 (1.0)	1.1 (1.0)	1.1 (1.0)	1.1 (1.0)	1.1 (1.0)

The varnished copper wire is F class insulation.

AM-60~370 motor has magnet brake option. The brake torque is 25Kg-cm (21.6in-lb) and BL driver offers 24VDC to control it directly.

Rated Power	W	750	1000	1500	2200
Motor No.		AM-750M/H CM-750L/HX	AM-1000M/H	AM-1500M/H CM-1500L/HX	AM-2200M/H CM-2200L/HX
Drive No.		BL2-107	BL2-115	BL2-115	BL2-122
Input Voltage		220V ± 10% 1			
Input Frequency	HZ	50 / 60			
Max. input current		16	20.4	26	38
Motor Phase		3			
Rated Torque	Kg-cm (in-lb)	AM:24.4/12.2 (21.1/10.6) CM:36.6/12.2 (31.7/10.6)	AM:32.5/16.2 (28.2/14.0)	AM:48.8/24.4 (42.3/21.1) CM:73.2/24.4 (63.4/21.1)	AM:73.2/36.6 (63.4/31.7) CM:109.8/36.6 (95.1/31.7)
Rated Speed	RPM	L/M/H/HX : 2000/3000/6000/6000			
Max. Efficiency	%	> 85	> 85	> 85	> 85
Max. Output	W	1600	2300	3000	4000
Max. Torque	Kg-cm (in-lb)	AM:70.0/35.0 (60.6/30.3) CM:95.0/24.0 (82.3/20.8)	AM:110.0/55.0 (95.3/47.6)	AM:120.0/60.0 (103.9/52.0) CM:160.0/45.0 (138.6/39.0)	AM:180.0/90.0 (155.9/77.9) CM:210.0/72.0 (181.9/62.4)
Variable Speed Range	RPM	L : 0~2000 M : 0~3000 H : 0~6000			
Acc. Dec. Time		0.1 ~ 600.0 Sec			
Speed regulation	Load	±1% Below (0~Rated Torque at rated speed)			
	Voltage	±1% Below (Source voltage± 10% at rated speed No Load)			
	Temperature	±1% Below (-10~45 / 14~113 at rated speed No Load)			
Motor Insulation/ Max. Working TEMP.		B Class (130 /266) / Max 100 /212			
Type of control		Rectangular wave PWM			
Speed command		1. Built-in potentiometer 2. External Potentiometer 2 k 3. 0~5VDC, 0~10VDC, 4~20mA control 4. RS485			
Operation		1. Pannel : CW、CCW、Key 2. Terminal : Type of input : Photocoupler, input impedance 2.2 k / CW、CCW、Common (4.5 ~ 5VDC) 3. Communication : RS485			
Output signal		Open collect output, External use condition DC5V、10mA below SPEED OUT、Fault relay A/B			
Protection		Any phenomenons as below will come to stop output alarm signal will be output and the motor. ● Over load : Motor working temperature is not over 100 (212). ● Over heat : Power modular over heat shut down itself. ● Lost phase : Motor signals are abnormal, due to motor cables was broken or disconnector. ● Phase to phase short circuit.			
Motor enclosure type		L/M:IP54		H/HX:IP40	
Figure No.		AM:6 CM:A/D	AM:7	AM:8 CM:B/E	AM:9 CM:C/F
Motor Weight	Kg (lb)	AM:8.0/7.8 (6.9/6.8) CM:11.0/14.2 (9.5/12.3)	AM:9.4/8.7 (8.1/7.5)	AM:11.0/9.7 (9.5/8.4) CM:14.0/15.3 (12.0/13.2)	AM:13.2/16.5 (11.4/14.3) CM:15.6/16.5 (13.5/14.3)
BL Driver Weight	Kg (lb)	1.3 (1.1)	1.3 (1.1)	1.3 (1.1)	1.3 (1.1)

AM-750~2200 has magnet brake option. The brake torque is 160Kg-cm(135in-lb).

5. Dimensions

5-1 Drive dimensions

BL2-101~107

Unit : mm

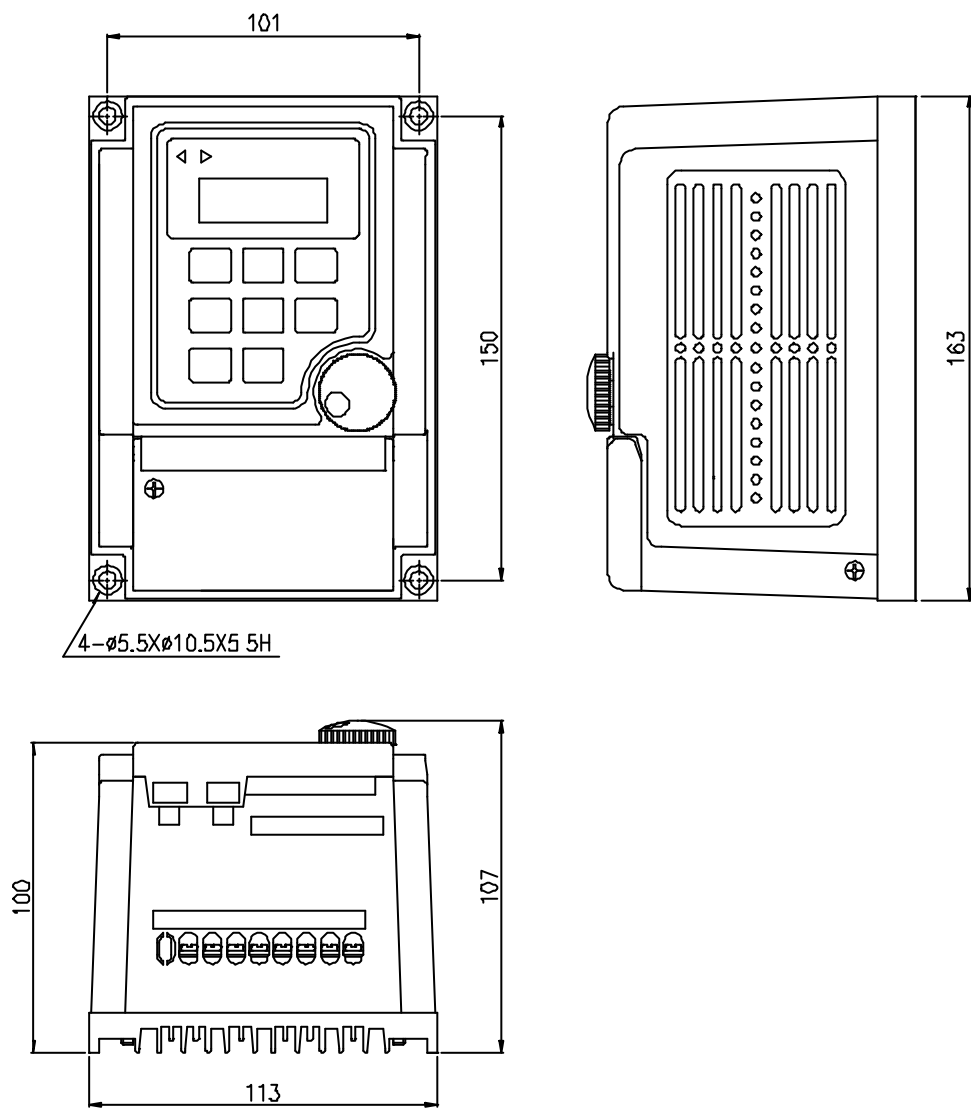

BL2-115~BL2-122

Unit : mm

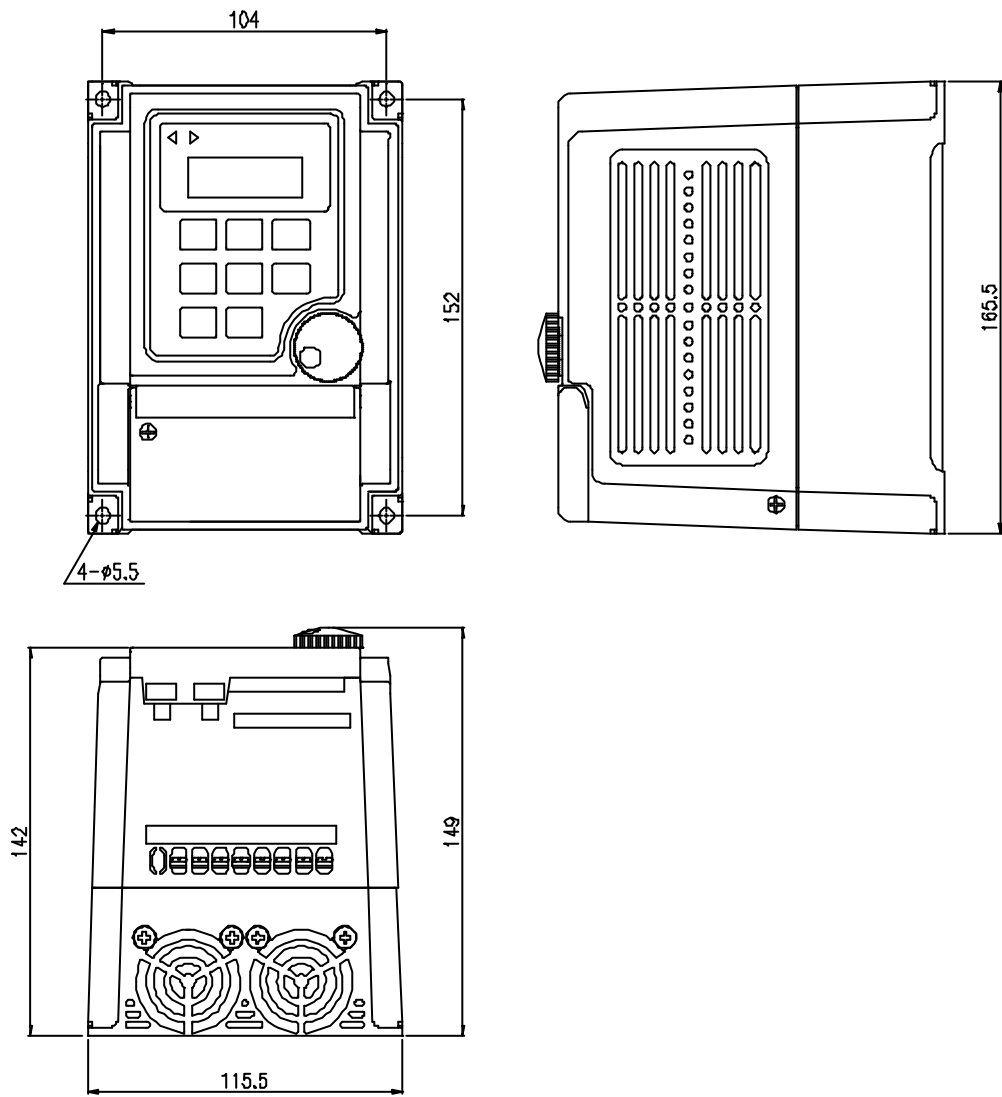

5-2 Motor dimensions
AM-60~370

Unit : mm

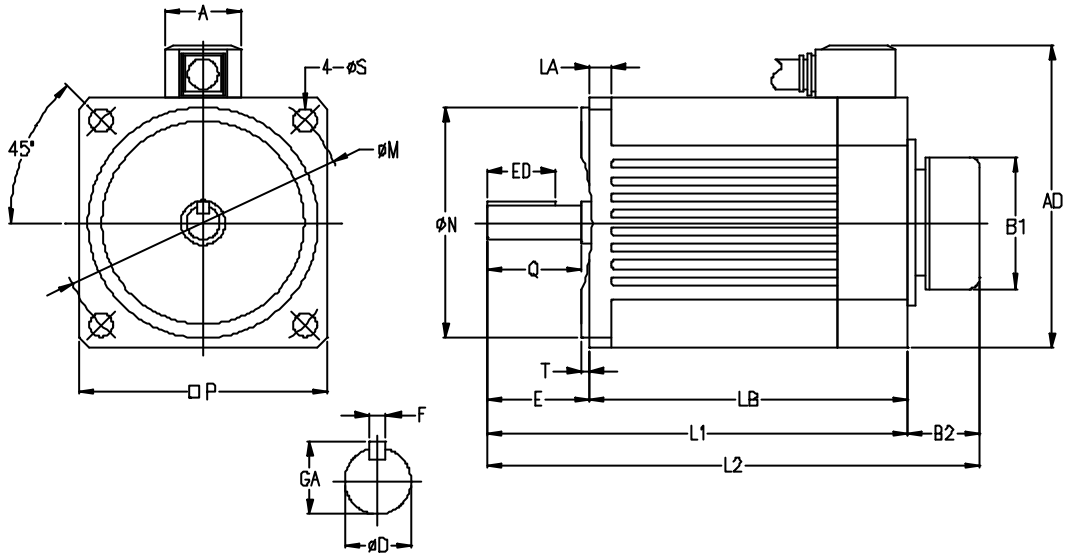

Wires colors : U(red), V(white), W(black).

No.	P	M	S	N	T	LA	LB	L1	L2	AD	A	B1	B2	OUTPUT SHAFT END					
														ED	Q	E	D	GA	F
1	90	104	8.5	83	2.5	8	100	128	161	109	27	61	33	20	25	28	12	13.5	4
2							115	147	180					25	29	32			
3							170	202	235					14	16	5			
4							185	217	250										
5																			

AM-750~AM-2200

Unit : mm

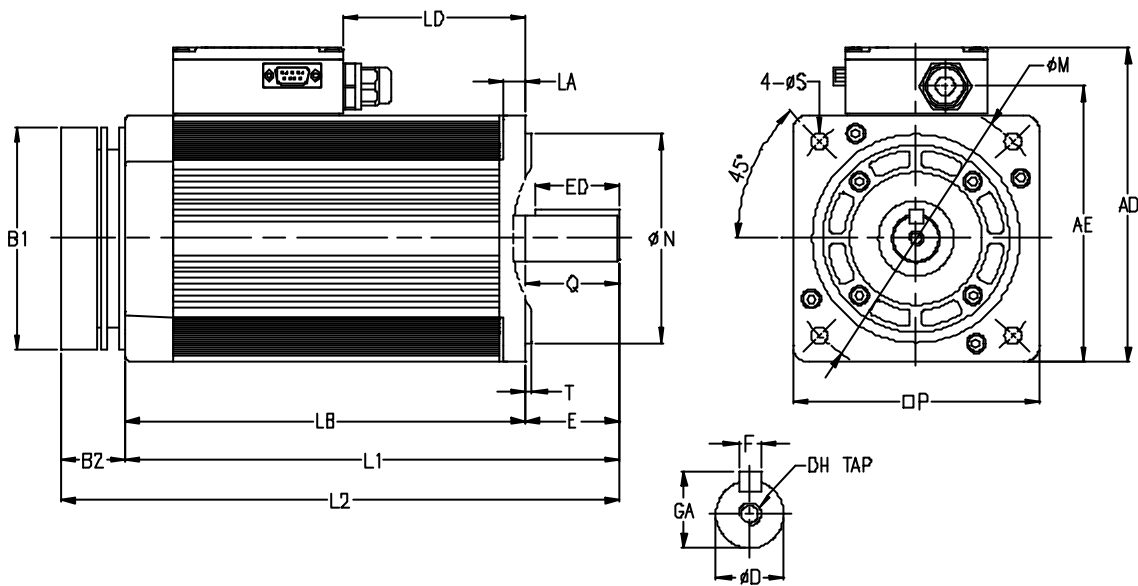

No.	P	M	S	N	T	LA	LB	L1	L2	B1	B2	AD	AE	LD	OUTPUT SHAFT END						
															ED	Q	E	D	GA	F	DH
6	130	145	9	110	3.5	12	178	218	252.3	117	34.3	165.5	146	63	35	40	40	19	21.5	6	M6
7							195	245	279.3					80							
8							212	262	296.3					97	45	50	50	24	27	8	M8
9							232	282	316.3					117							

CM-750~CM-2200

Unit : mm

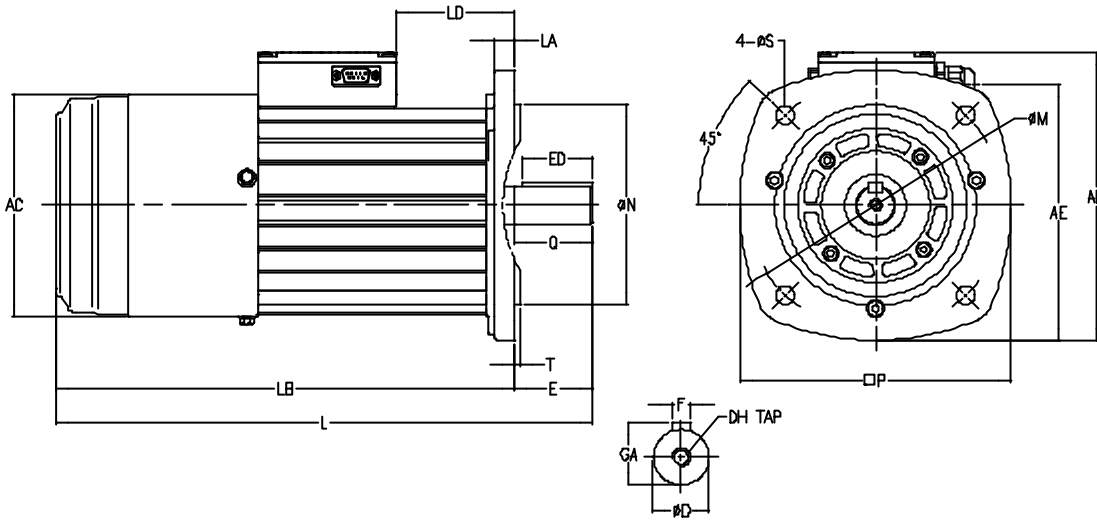

No.	P	M	S	N	T	LA	LB	L	AC	AD	AE	LD	OUTPUT SHAFT END						
													ED	Q	E	D	GA	F	DF
A	175	165	12	130	3.5	13	205	245	142	186	166	67	35	40	40	19	21.5	6	M6
B							239	289				101	45	50	50	24	27	8	M8
C							259	309				121	45	50	50	24	27	8	M8
D							287	327	67			35	40	40	19	21.5	6	M6	
E								337				45	50	50	24	27	8	M8	
F								296				346	76	45	50	50	24	27	8

5-2 F306 dimensions

Unit : mm

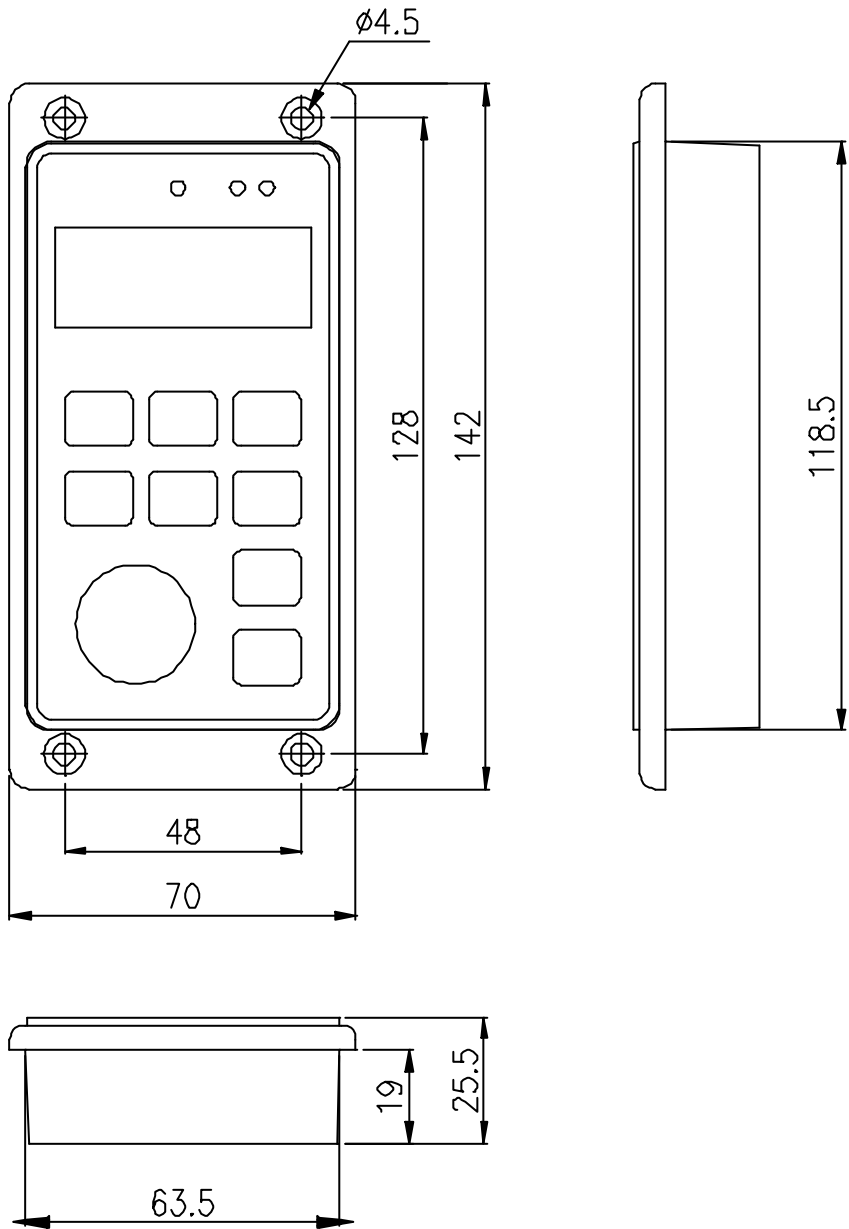

6. Digital operation panel

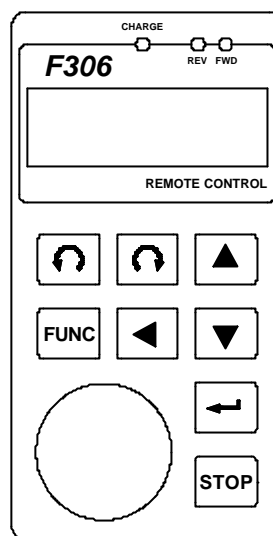
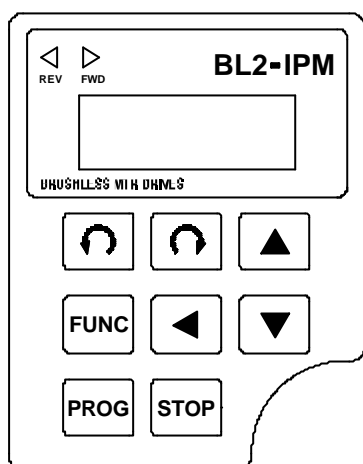

Keypad	Function	Description
	Forward run	Commands forward run
	Reverse run	Commands reverse run
	Cursor movement	Select the digit
	Down	Decrease the parameter value 9~0
	Up	Increase the parameter value 0~9
	Memory storage	Saves the setting parameter value
	Function	Press once to select function code and press again to change its content
	Stop	Stop operation / Escape to standby mode

Note for HX RPM number on display:

The RPM number has been divided by 10. Ex, CD04=26 means CD04=260RPM. This division does not effect on RS485 communication. It is for display only.

7. Terminals and wiring

7-1 Main power circuit terminals

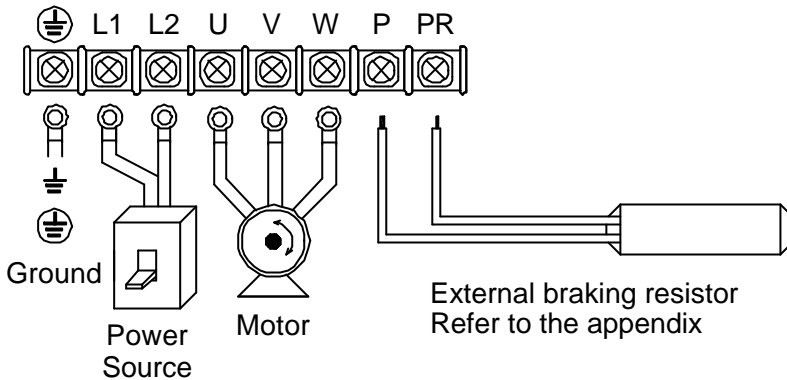

Main circuit terminal			
No.	Symbol	Terminal name	Description
1		Ground	Ground (Earth) Terminal
2	L1	Connect power supply	(L1, L2) Single Phase
3	L2		
4	U	Driver output	Terminal connecting to motor U(red), V(white), W(black)
5	V		
6	W		
7	P	Dynamic brake resistor	See appendix for braking resistor selection
8	PR		

7-2 Control terminals

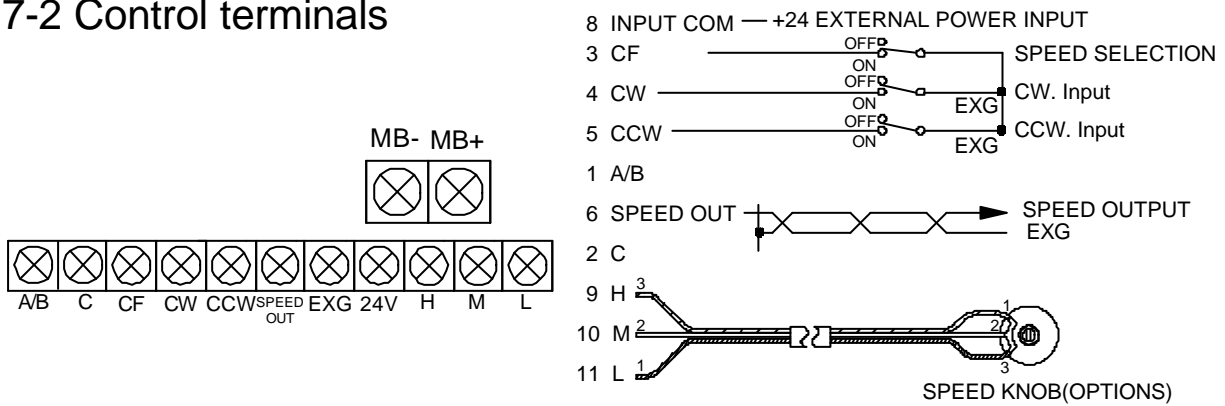

7-3 Control terminals descriptions

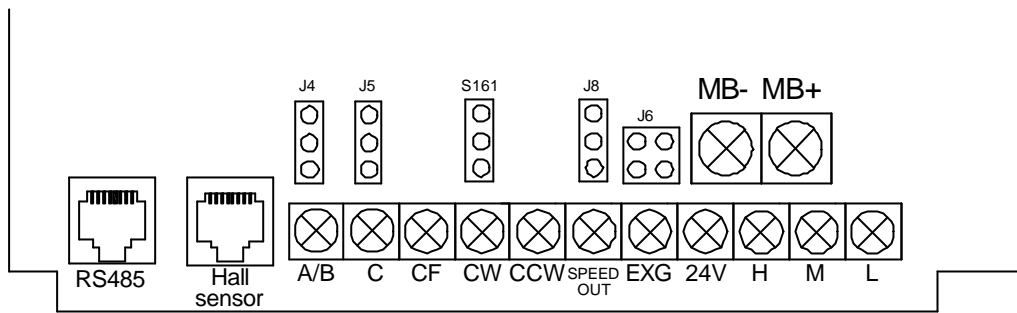

All terminal can connect to switch, relay, TTL or Transistor. Refer to 8-3 for detail.

No	Symbol	Terminal name	Description
1	A/B	Alarm output	Fault alarm contact. Set J4 jumper for A (normal open) or B (normal close).
2	C	Alarm output common	Fault alarm contact C.
3	CF	Analog and digital speed input selection	CF/EXG open : Analog speed input is from panel VR or F306 VR. Digital speed input is CD28 setting. Set J5 jumper for panel VR or F306 VR selection. CF/EXG short : Analog speed input is from external VR by H M L terminals. Digital speed input is CD29 setting.
4	CW	Forward operation	Forward operation / stop terminal.
5	CCW	Reverse operation	Reverse operation / stop terminal.
6	SPEED OUT	Speed signal output	L, M model : 12 pulses/turn H, HX model : 6 pulses/turn
7	EXG	Common terminal	Common for terminal 3~6.
8	24V	Input COM	+24VDC external power input. Set S161 jumper to select internal or external power.
9	H	+10 VDC	External VR reference voltage.
10	M	Analog command input	External analog speed command input. Set J6 jumper for voltage 0~5VDC, 0~10VDC or 4~20mA.
11	L	H and M common	
	MB-	Motor brake -	24VDC, 15W
	MB+	Motor brake +	

7-4 Jumpers

- a. S161 for INT/EXT reference voltage input
(Default value is INT reference voltage input)

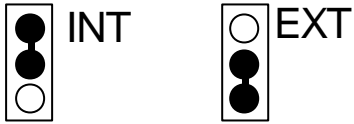

- b. J5 for panel VR or F306 VR (Default value is panel VR)



- c. J4 for fault alarm A (normal open) or B (normal close)
(Default value is fault alarm A.)

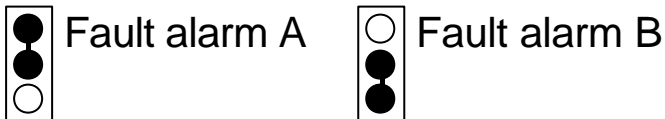

- d. J8 for external speed command voltage 0~5V or 0~10V
(Default value is 0~10V)

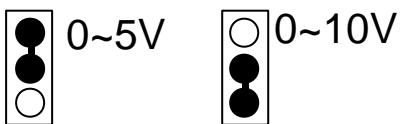

- e. J6 for H M L input signal selection
(Default value is 0~10V)

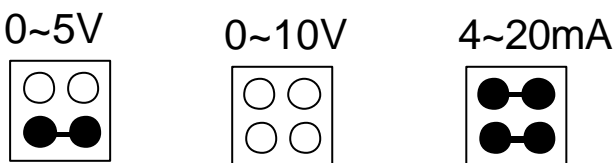

7-5 Hall sensor connector

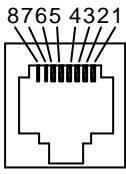

NO	8	7	6	5	4	3	2	1
Color	Black	Red	Brown	Green	Yellow	Orange	Purple	Blue
Symbol	GND	VCC		HC	HB	HA	TH2	TH1
	Connect to Hall sensor / NTC							

7-6 RS485 connector

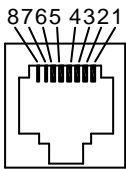

NO	8	7	6	5	4	3	2	1
Color	Black	Red	Orange	Yellow	Green	Blue	Purple	Brown
Symbol	GND	VCC	GND	A	RFA0	B	3.3V	
	Connect to F306 or RS485							

This connector is for both F306 and RS485. Set CD02 for selection.

7-7 Wiring

7-7-1 Wiring for main circuit

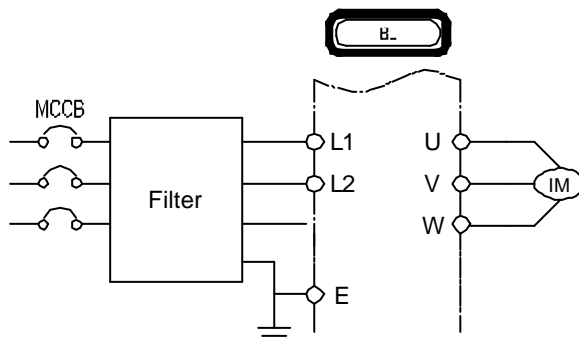

7-7-2 Wiring equipments

Select the wiring equipment, refer to the table below.

1. On the input power side, a molded case circuit breaker (MCCB) to protect driver primary wiring should be installed.
2. A leakage current breaker threshold of 200mA and above is recommended.
3. Use of input side magnetic contactor. An input MC can be used to prevent an automatic restart after recovery from an external power loss during remote control operation. However, do not use the MC reduced reliability.
4. In general, magnetic contactors on the output of the driver should not be used for motor control. Starting a motor with the driver running will cause large surge currents and the driver overcurrent protector to trigger.

Model	BL2					
Model No	01	02	04	07	15	22
Capacity (KVA)	1.0	1.0	1.0	1.6	2.7	3.8
Current (A)	2.5	2.5	2.5	4.1	7	10
Circuit Breaker (MCCB) (A)	10	10	10	10	15	20
Electro-Magnetic Contactor (A)	12	12	12	12	12	12
Thermal relay RC value (A)	2.4	2.4	2.4	3.8	6.8	9

7-7-3 Wiring and cautionary points

A. Main circuit

1. Don't connect the cables of the power supply side to the U, V and W output terminals for the motor.
2. Don't connect any electromagnetic contactor between the driver and motor.
3. Don't put the advance phase capacitor between the driver and motor.
4. Put MCCB in the input power supply.

B. Control signal circuit

1. Separate the power cables of main circuit etc. from the control cables of the sequence and analog signals by passing the cables through the different ducts.
2. Use twisted pair shielded wire for control signal and connect the shield to earth terminal at on end, COMMON terminal of control board. Leave the other end of shielding open.
3. Avoid common Ground leads between high and low level voltage equipment.

C. Grounding

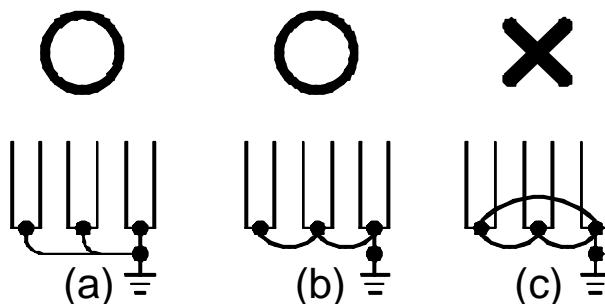

1. Be sure ground both the driver and motor.
2. Keep grounded leads as short as possible.
3. Shield cables used to protect low-level signal leads should grounded at on end point.
4. Provide class 3 grounding (0.1 or less) for a terminal.
5. When grounding several drivers, make connections as shown below, no loop is produced as shown in FIG "a", FIG "b".



8 Operation and connection

8-1 Parameter list

Display code	Function	Default Value	Adjust Range	Unit	Remark
CD01	Reserved				
CD02	Command mode	1	0~7		0~3 : Close loop control 4~7 : Open loop control
CD03	Brake mode	1	0~1		0 : Free run to stop 1 : Stop with deceleration time
CD04	Maximum speed limited	2000/3000/6000 HX:15000	130~6000 HX:260~15000	RPM	
CD05	Minimum speed limited	0	0~6000 HX:0~15000	RPM	
CD06	Speed command RPM/5V	2000/3000/6000 HX:15000	1000~7000 HX:1000~15000	RPM	
CD07	Speed command RPM/0V	0	-500~500 HX:-1500~1500	RPM	
CD08	Acceleration time	0.2	0.1~600.0	SEC	
CD09	Deceleration time	0.2	0.1~600.0	SEC	
CD10	S curve	3.0	0.2~15.0		
CD11	4~20mA	0	0~1		
CD12	K_p (P gain)	100	10~200	mv/RPM	
CD13	K_i (I gain)	80	30~300	ms	
CD14	Hall sensor position off set shift	10	0~30		
CD15	Display ratio	1	1~200		

Display code	Function	Default Value	Adjust Range	Unit	Remark
CD16	ACC./DEC. curve	0	0~1		0 : Linear 1 : S curve
CD17	Current limit	300/270	20~300/20~270	%	750W : 300% > 750W : 270%
CD18	Direction limit	4	0~7		0 : CW and CCW, need  before change direct 1 : CW only 2 : CCW only 4 : CW and CCW, do not need  before change direction
CD19	Analog/digital speed input	0	0~1		
CD20	Fast stop	0	0 or 1		
CD21	Address setting	1	0~99		
CD22	Transmission speed	3	0~3		
CD23	Transmission fault treatment	3	0~3		
CD24	Communicator protocol	0	0~11		
CD25	Communication loss time detect	0.5	0.1~100.0	SEC	
CD26	Communication loss	3	0~3		
CD27	Communication error detect	3	1~10		

Display code	Function	Default Value	Adjust Range	Unit	Remark
CD28	1 st speed in digital	1000	0~6000 / 0~15000	RPM	
CD29	2 nd speed in digital	2000	0~6000 / 0~15000	RPM	
CD30	Reset to default	0	0 or 1		















Communication address description

Display code	Function	Default Value	Adjust Range	Unit	Remark
99	RS485 speed command	0	0~6000 / 0~15000	RPM	
100	RS485 operating command		0~3		
101	Motor speed (RPM)				
102	Motor ranning condition		0~3		
103	Error code		1~9		

Note :

1. It needs to reset driver (turn off and turn on power) to effect CD02 new setting.
2. CD04, CD05, CD06, CD07, CD12, CD13, CD28, CD29 are inactive in open loop control mode.

8-2 Parameter setting sequence

- A. In standby condition, press  to be in setting model. Press  if it is not in standby mode.
- B. Press    to the parameter number. Press  to return to standby mode if there is no need to change value.
- C. Press  to show parameter setting value. Press  to return to parameter number and press  to return to standby mode, if there is no need to change value.
- D. Press    to the need value.
- E. Press  to save changes and return to standby mode.
- F. Press  or  to operate motor.

Note for HX RPM number on display:

The RPM number has been divided by 10. Ex, CD04=26 means CD04=260RPM. This division does not effect on RS485 communication. It is for display only.

8-3 Command source setting

Panel, terminal, RS485 and remote control (F306) are the command source for selection. Use CD02 to select it. Panel command is effective always.











A. Panel

a. Analog/digital speed input

a-1. CD19=0 analog input

- Panel's VR is 1st speed. Display is flashing to show the setting speed.
- Analog input on H M L terminal is 2nd speed. Set CF/COM close to select 2nd speed. Display is flashing to show the setting speed.

a-2. CD19=1 digital input

- 1st speed is CD28 value and 2nd speed is CD29 value. Use    to set speed, then press  to save setting. Set CF/COM close to select CD29 2nd speed.
- Use   can change speed in operation condition in digital speed input mode. Press  or  to change speed. Repeat to press  or  if it does not response in 5 seconds. In the speed change mode:
 - (1) Press keypad once : change 1 RPM intermittently.
 - (2) Continue to press keypad : change 1 RPM in first 10 seconds and change 10 RPM after first 10 seconds.

b. Press  or  to operate motor.

c. Press  to stop motor.

d. Use CF terminals to do two speeds control. CF/COM open is 1st speed. CF/COM close is 2nd speed.

B. Remote control (F306)

Same as Panel control.

C. Communication (RS485)

Please refer to CD21 to address 103 for detail description.

D. Terminal control

1. Set CD02=0 or 4.
2. Set S161 jumper at INT if using internal power.
3. Example : 1st and 2nd speed control.

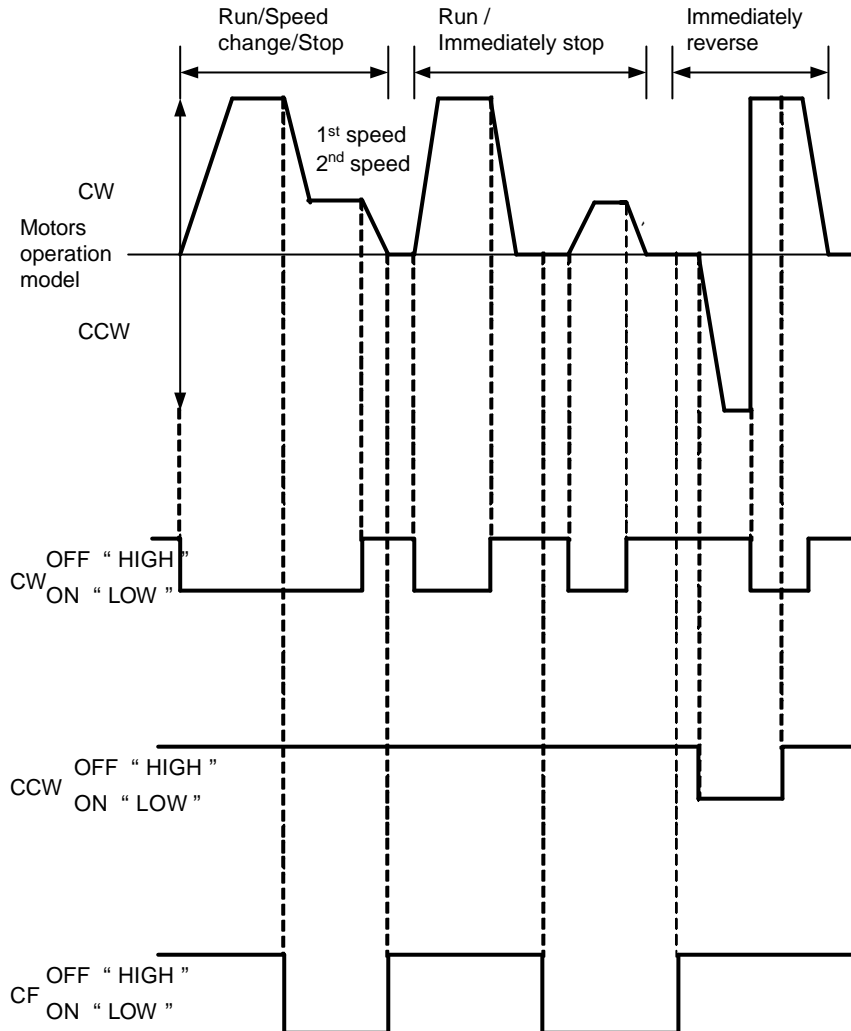

Note :

- a. Use CW/CCW switch to control motors RUN/STOP. Do not use power ON/OFF to control motors RUN/STOP.
- b. Motor follows the ACC./DEC. time if CW/CCW is switched during operation.
- c. Analog input : Panel VR or F306 VR is 1st speed and HML command is 2nd speed.
- d. Digital input : CD28 setting is 1st speed and CD29 setting is 2nd speed.

3.Signal input circuit

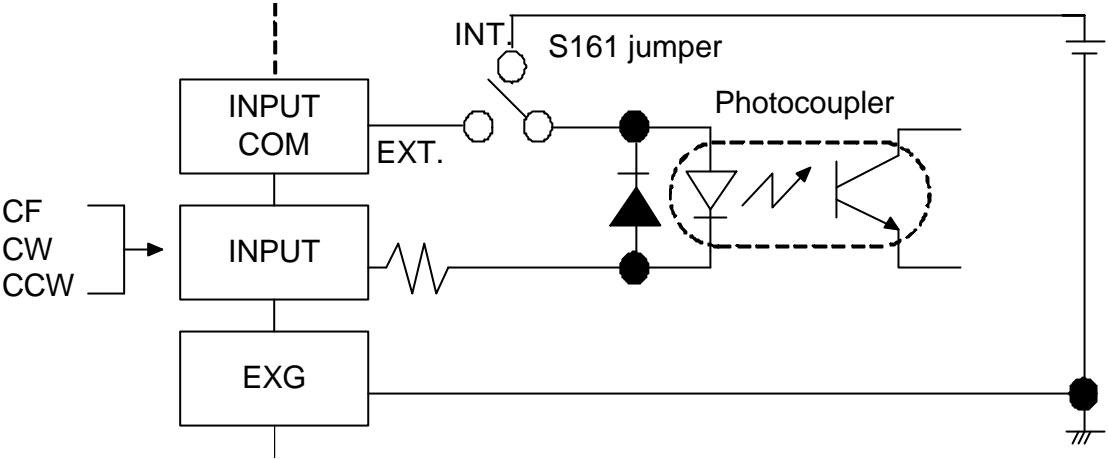

EXT voltage is 24VDC $\pm 10\%$
 Using internal power supply control
 Set S161 jumper at INT. motor cannot operate if S161 jumper is at EXT.
 <Non-contact control>

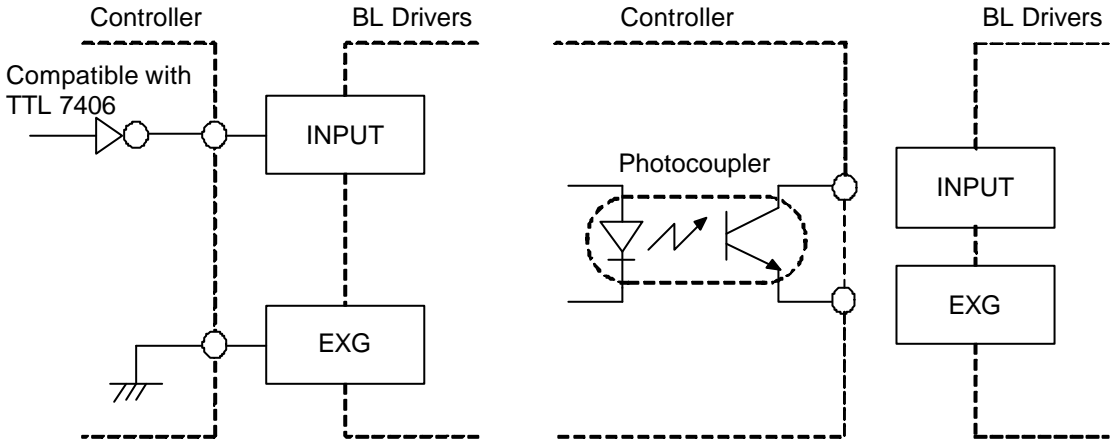

<Contact control>

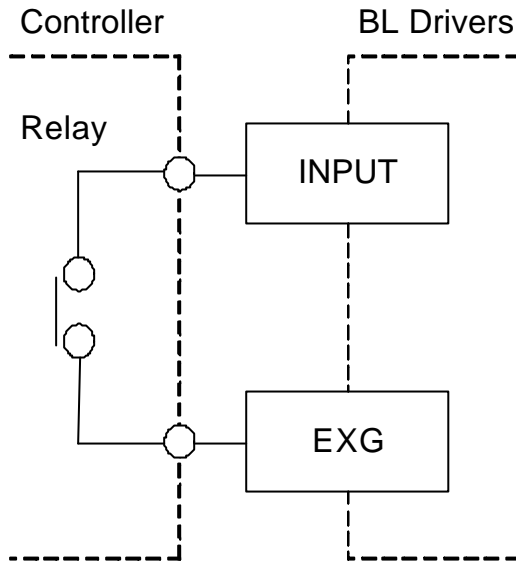

Using external power supply control

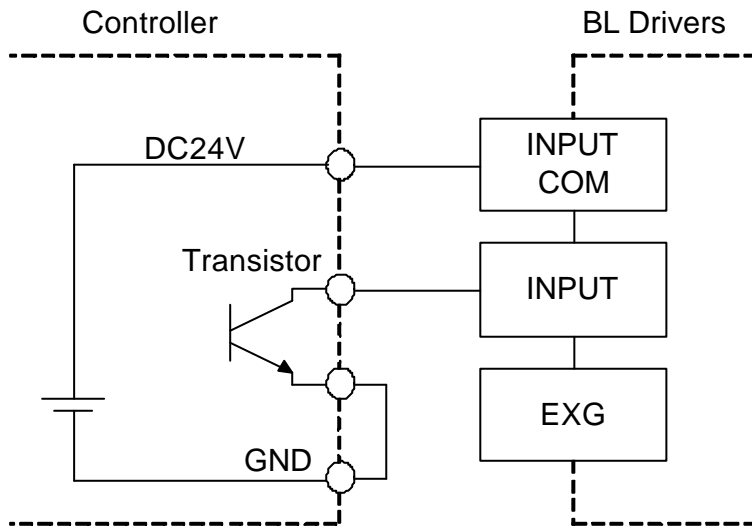

Set S161 jumper at INT.

Note : controller with built-in clamp diode

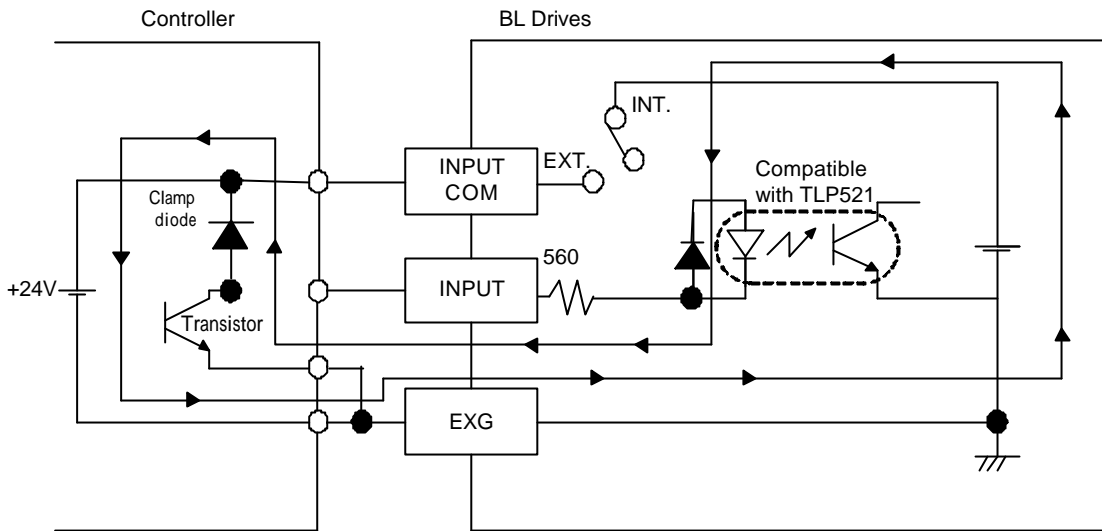

It is necessary to set S161 jumper at EXT, when controller with built-in clamp diode has been used. If S161 jumper setting is not correct, then motors will run at controller power ON/OFF.

4.Signal output circuit

4-1 Signal output circuit

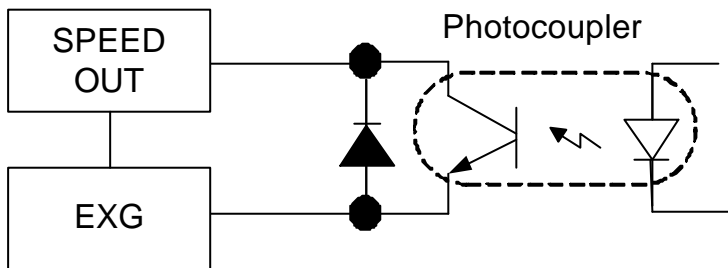

- External power supply DC voltage should less than 26.4V and current should less than 10mA.
- Select suitable current limit resistor based on DC power supply voltage.

4-2 Example of application of signal output circuit

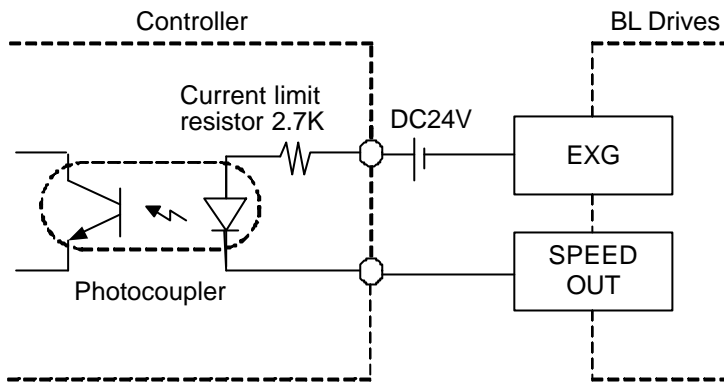

[Speed out]

H, HX series : 6 pulses/per turn

L, M series : 12 pulses/per turn

Motor speed can be measured from the frequencies of terminal "SPEED OUT".

$$\text{Motor speed(r/min)} = \frac{\text{Frequency of speed out (HZ)}}{6 \text{ or } 12} \times 60$$

$$\frac{1}{T} = \text{Frequency of speed out}$$

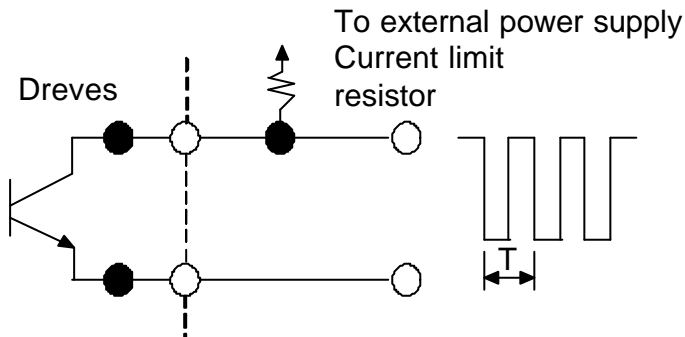

The pulse width depends on the motor speed.

That is, the faster the motor runs, the narrower the width is.

[Alarm Out]

1. Any fault occurs, alarm will output.
2. Set J4 jumper for A (normal open) or B (normal close).
3. Regarding type of protection, please refer to "TROUBLE SHOOTING".

8-4 Parameter description

Command mode
CD02

Setting Range	0 ~ 7
Default value	1

- 0 : Terminal command in close loop control.
- 1 : Panel or F306 command in close loop control. (Default value)
- 2 : Panel or communicator command in close loop control.
- 3 : Speed command by RS485 and operate command by terminal in close loop control.
- 4 : Terminal command in open loop control.
- 5 : Panel or F306 command in open loop control.
- 6 : Panel or communicator command in open loop control.
- 7 : Speed command by RS485 and operate command by terminal in open loop control.

- Note :
- 1. New setting needs to be effected by reset driver (turn off and turn on power)
 - 2. In mode 4~7, display shows DUTY in standby mode and motor real speed in running mode.
 - 3. In mode 4~7, the speed duty can be set by panel VR or HML external analog signal only.

Brake mode
CD03

Setting Range	0 ~ 1
Default value	1

- 0 : Free run to stop.
- 1 : Stop with deceleration time. (Default value)

Maximum speed limit
CD04

Setting Range	130 ~ 6000 / 260 ~ 15000
Default value	2000(L) / 3000(M) / 6000(H) /15000(HX)

Note : This parameter does not work in open loop control.

Ex. CD04=2500

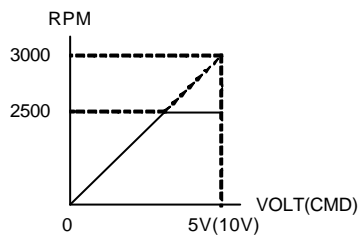

Minimum speed limit
CD05

Setting Range	0 ~ 6000 / 0 ~ 15000
Default value	0

Ex. CD05=300

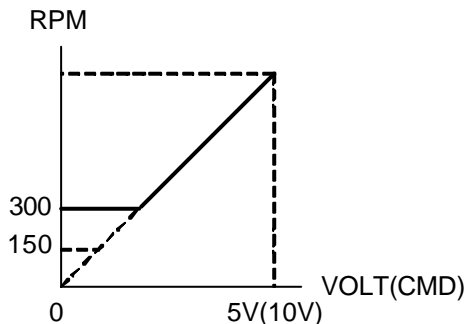

To get better close loop control performance, the L/M series need to set over 150RPM and the H/HX series need to set over 300RPM. Please note, the L/M series cannot work at 1~129RPM and the H/HX series cannot work at 1~259RPM.

Note : This parameter does not work in open loop control.

Speed command RPM / 5V
CD06

Setting Range	1000 ~ 7000 / 1000 ~ 15000
Default value	2000/3000/6000/ 15000

The reference speed command at 5V(10V)(20mA) in close loop.
 Note : This parameter does not work in open loop control.

Speed command RPM / 0V
CD07

Setting Range	-500 ~ 500 / -1500 ~ 1500
Default value	0

The reference speed command at 0V/4mA in close loop.
 Note : This parameter does not work in open loop control.

Ex. 2000RPM at 4.5V, 0RPM at 0.5V

CD06=2250, CD07=-250, CD04=2000

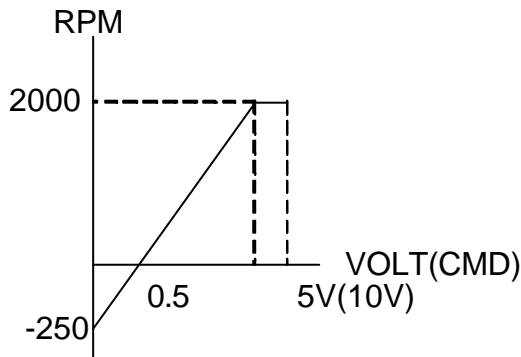

Acceleration time
CD08

Setting Range	0.1 ~ 600.0 second
Default value	0.2 seconds

The acceleration time from 0 RPM to CD04 RPM. The acceleration time is influenced with the value of S curve, K_p and K_i .

Deceleration time
CD09

Setting Range	0.1 ~ 600.0 second
Default value	0.2 seconds

The deceleration time CD04 RPM to 0 RPM. The deceleration time is influenced with the value of S curve, K_p and K_i .

Note : If CD09=0.2 is still too slow, set CD20=1.

S curve
CD10

Setting Range	0.2 ~ 15.0
Default value	3.0

Set soft acceleration/deceleration operation. The real acceleration/deceleration time will be longer than CD08 and CD09 setting if set CD16=1.

4~20mA
CD11

Setting Range	0 ~ 1
Default value	0

0 : Normal(HML analog input)(Default value)

1 : 4~20mA

K_p (P gain)
CD12

Setting Range	10 ~ 200
Default value	100

Higher value is with faster response, it can be overshoot if value is too high. This parameter does not work in open loop control.

K_I (I gain)
CD13

Setting Range	30 ~ 300 ms
Default value	80 ms

Lower value is with faster response. This parameter does not work in open loop control.

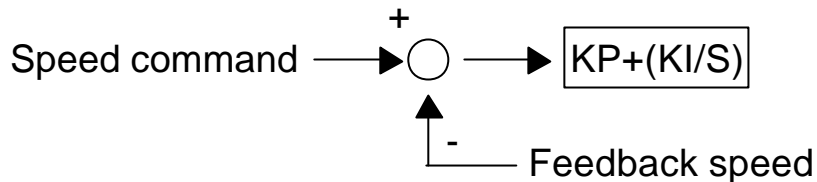

Hall sensor position off set shift
CD14

Setting Range	0 ~ 30
Default value	10

Adjust motor hall sensor position in phase advance. Positive value is phase advance for CW operation. Current signal may be in phase behind condition when motor is running at high speed. This parameter can improve performance.

Display ratio
CD15

Setting Range	1 ~ 200
Default value	1

Display speed = (set or real speed) / CD15
 This function is good for motor with gearbox. The display can show the gearbox output speed.

ACC./DEC. curve
CD16

Setting Range	0 ~ 1
Default value	0

0 : Linear. (Default value)
 1 : S curve.

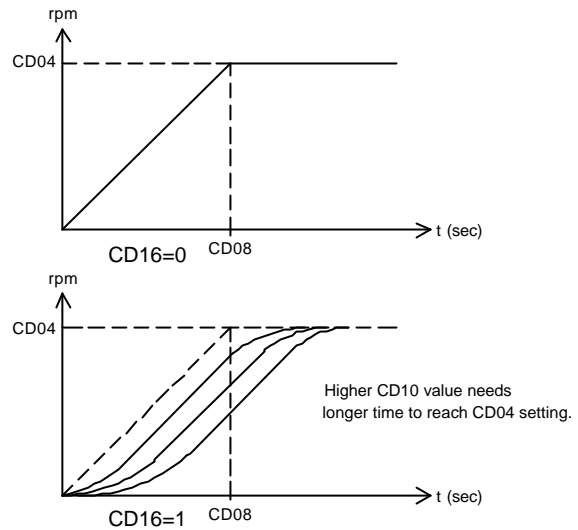

Current limit
CD17

Setting Range	20 ~ 300% or 20 ~ 270%
Default value	300 / 270%

Higher value has higher output torque, but it may occur overheat problem.

Setting range : 750W : 300%
 > 750W : 270%

Direction limit
CD18

Setting Range	0 ~ 7
Default value	4

0 : CW and CCW, need before change direct.
 1 : CW only.
 2 : CCW only.
 4 : CW and CCW, do not need before change direction.
 5~7 : Reserved.

Analog / digital speed input
CD19

Setting Range	0 ~ 1
Default value	0

0 : Analog command is from pannel/F306 VR or H M L terminal.
 1: Digital command is from panel or F306 and worked with CD28
 or CD29 setting.

Fast stop
CD20

Setting Range	0 or 1
Default value	0

CD20=0: Deceleration time is following CD09 setting.
 CD20=1: Motor speed is decelerating by maximum ability.

Address setting
CD21

Setting Range	0 ~ 99
Default value	1

Each drive must have unique identified address if they are controlled by RS-485 communication. Each address cannot be duplicated.

Transmission speed
CD22

Setting Range	0 ~ 3
Default value	3

Setting the transmission speed between computer and drive.
 0 : 2400 bits/second.
 1 : 4800 bits/second.
 2 : 9600 bits/second.
 3 : 19200 bits/second.

Transmission fault treatment
CD23

Setting Range	0 ~ 3
Default value	3

- 0 : Alarm and keep operation.
- 1 : Alarm and decelerate to stop.
- 2 : Alarm and free run to stop.
- 3 : No alarm and keep operation.

Communicator protocol
CD24

Setting Range	0 ~ 11
Default value	0

A. Data format

- 0 : 8,N,1 RTU (1 start bit+8 data bits+1 stop bit)
8,N,1 RTU(10bits)(character frame in hexadecimal)

Start bit	0	1	2	3	4	5	6	7	Stop bit
-----------	---	---	---	---	---	---	---	---	----------

- 1 : 8,N,2 RTU (1 start bit+8 data bits+2 stop bit)
8,N,2 RTU(11bits)(character frame in hexadecimal)

Start bit	0	1	2	3	4	5	6	7	Stop bit	Stop bit
-----------	---	---	---	---	---	---	---	---	----------	----------

- 2 : 8,E,1 RTU (1 start bit+8 data bits+1 Even bit+1 stop bit)
8,E,1 RTU(11bits)(character frame in hexadecimal)

Start bit	0	1	2	3	4	5	6	7	Even parity	Stop bit
-----------	---	---	---	---	---	---	---	---	-------------	----------

- 3 : 8,O,1 RTU (1 start bit+8 data bits+1 Odd bit+1 stop bit)
8,O,1 RTU(11bits)(character frame in hexadecimal)

Start bit	0	1	2	3	4	5	6	7	Odd parity	Stop bit
-----------	---	---	---	---	---	---	---	---	------------	----------

4 : 7,N,1 ASCII (1 start bit+7 data bits+1 stop bit)
 7,N,1 ASCII(9bits)(character frame in hexadecimal)

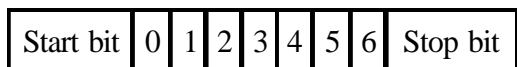

5 : 7,N,2 ASCII (1 start bit+7 data bits+2 stop bit)
 7,N,2 ASCII(10bits)(character frame in hexadecimal)

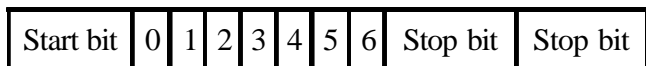

6 : 7,E,1 ASCII (1 start bit+7 data bits+1 Even bit+1 stop bit)
 7,E,1 ASCII(10bits)(character frame in hexadecimal)

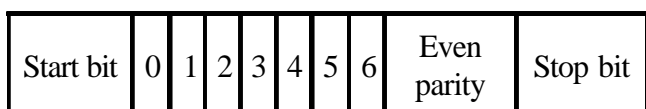

7 : 7,O,1 ASCII (1 start bit+7 data bits+1 Odd bit+1 stop bit)
 7,O,1 ASCII(10bits)(character frame in hexadecimal)

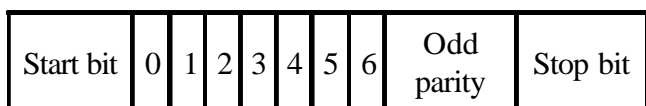

8 : 8,N,1 ASCII (1 start bit+8 data bits+1 stop bit)
 8,N,1 ASCII(10bits)(character frame in hexadecimal)

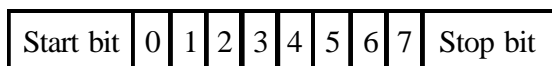

9 : 8,N,2 ASCII (1 start bit+8 data bits+2 stop bit)
 8,N,2 ASCII(11bits)(character frame in hexadecimal)

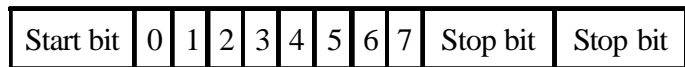

10 : 8,E,1 ASCII (1 start bit+8 data bits+1 Even bit+1 stop bit)
 8,E,1 ASCII(11bits)(character frame in hexadecimal)

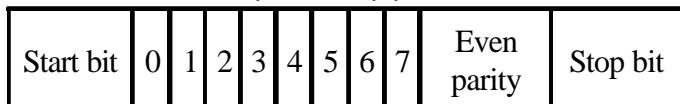

11 : 8,O,1 ASCII (1 start bit+8 data bits+1 Odd bit+1 stop bit)
 8,O,1 ASCII(11bits)(character frame in hexadecimal)

Start bit	0	1	2	3	4	5	6	7	Odd parity	Stop bit
-----------	---	---	---	---	---	---	---	---	------------	----------

B. Communication protocol

Data contents are in hexadecimal with positive and negative format.

1. RTU

Start	A silent interval of more than 10ms
Address	8-bit address
Function	8-bit command
Data (n-1)	Contents of data : n*8-bit data, n ≤ 30
...	
Data 0	
CRC CHK Low	Check sum (CRCL)
CRC CHK High	Check sum (CRCH)
End	A silent interval of more than 10ms

2. ASCII

STX	Start character=' : ' (3AH)
Address Hi	Communication address : 8-bit address consists of 2 ASCII codes.
Address Lo	
Function Hi	Command code : 8-bit command consists of 2 ASCII codes.
Function Lo	
Data (n-1)	Contents of data : n*8-bit data consist of 2n ASCII codes. (n = 30)
...	
Data 0	
LRC CHK High	LRC check sum : 8-bit check sum consists of 2 ASCII codes.
LRC CHK Low	
END Hi	End characters : END Hi=CR(0DH) END Lo=LF(0AH)
END Lo	

CRC(Cyclical Redundancy Check) is calculated by the following steps:

Step 1. Load a 16-bit register (called CRC register) with FFFFH.

Step 2. Exclusive OR the first 8-bit byte of the command message with the low order byte of the 16-bit CRC register, putting the result in the CRC register.

Step 3. Shift the CRC registers one bit to the right with MSB zero filling.

Extract and examine the LSB.

Step 4. If the LSB of CRC register is 0, repeat step 3, else Exclusive OR the CRC register with the polynomial value A001H.

Step 5. Repeat step 3 and 4 until eight shifts have been performed. When this is done, a complete 8-bit byte will have been processed.

Step 6. Repeat steps 2 to 5 for the next 8-bit byte of the command message. Continue doing this until all bytes have been processed.

The final contents of the CRC register are the CRC value.

LRC (Longitudinal Redundancy Check) is calculated by summing up, module 256, the values of the bytes from Address to last data character then calculating the hexadecimal representation of the 2's-complement negation of the sum.

For example, refer to 06H CD04

$$34+06+00+04+05+DC=1FH$$

$$\text{LRC HI}=E(45), \text{LRC LO}=1(33)$$

the 2's-complement negation of FH is E1H

C. ASCII code contrast

Value	0	1	2	3	4	5	6	7
ASCII code	30H	31H	32H	33H	34H	35H	36H	37H
Value	8	9	A	B	C	D	E	F
ASCII code	38H	39H	41H	42H	43H	44H	45H	46H

D. Function code

1. 03H : Read driver's setting
2. 06H : Write driver's setting or address
3. 08H : Communication loop detection

(1) 03H : Read drive's setting	
Computer command message	
D1 : Communication address	(00~FFh)
D2 : Function code	(03h)
D3 : Parameter number (H)	(00h)
D4 : Parameter number (L)	(0~67h)
D5 : Quantity of parameter (H) (word count)	(00h)
D6 : Quantity of parameter (L) (word count)	(00~10h)
D7 : CRCL or LRC (H)	(0~FFh)
D8 : CRCH or LRC (L)	(0~FFh)
Drive response message	
D1 : Communication address	(01~FFh)
D2 : Function code	(03h)
D3 : Quantity of parameter (byte count)	
D4 : Content of data (H)	(0~FFh)
D5 : Content of data (L)	(0~FFh)
D6 : Content of data (H)	(0~FFh)
D7 : Content of data (L)	(0~FFh)
Dn-1 : CRCL or LRC(H)	(0~FFh)
Dn : CRCH or LRC(L)	(0~FFh)

Ex. To read two parameter data address 99(63H)=1500(05DCH) and address 100(64H)=1(01H) from drive address 52(34H).

1.RTU

Computer command message			Drive response message		
D1	Address	34H	D1	Address	34H
D2	Function code	03H	D2	Function code	03H
D3	Start address (H)	00H	D3	Quantity of data (count by byte)	04H
D4	Start address (L)	63H	D4	CD99 content (H)	05H
D5	# of data (H)	00H	D5	CD99 content (L)	DCH
D6	# of data (L)	02H	D6	CD100 content (H)	00H
D7	CRCL	CRCL	D7	CD100 content (L)	01H
D8	CRCH	CRCH	D8	CRCL	CRCL
			D9	CRCH	CRCH

2. ASCII

Computer command message			Drive response message		
	STX	3A		STX	3A
D1	Address '3'	33	D1	Address '3'	33
	Address '4'	34		Address '4'	34
D2	Function '0'	30	D2	Function '0'	30
	Function '3'	33		Function '3'	33
D3	Start address '0'	30	D3	# of data '0'	30
	Start address '0'	30		count by byte '4'	34
D4	Start address '6'	36	D4	CD99 content '0'	30
	Start address '3'	33			CD99 content '5'
D5	# of data '0'	30	D5	CD99 content 'D'	44
	# of data '0'	30		CD99 content 'C'	43
D6	# of data '0'	30	D6	CD100 content '0'	30
	# of data '2'	32			CD100 content '0'
D7	LRC HI	LRC HI	D7	CD100 content '0'	30
D8	LRC LO	LRC LO		CD100 content '1'	31
	END HI	0D	D8	LRC HI	LRC HI
	END LO	0A	D9	LRC LO	LRC LO
				END HI	0D
				END LO	0A

Note 1 : The parameter values can be in integer, decimal and negative. Each value has different process to read and write.

Refer to 8-1 lists to find out the minimum unit and value range for each parameter.

a. In computer command message D5 80, this value is negative.

b. In drive response message,
Function code 03H : D(4+2n) 80, this value is negative.

Function code 06H, 08H : D(3+2n) 80, this value is negative.

All hexadecimal values have 4 numbers(note2~4), first two numbers are D4, last two numbers are D5.

Note 2 : Processing integer number

Transfer value into hexadecimal value. The first two numbers are D4 and the last two numbers are D5.

Ex. Speed=1710 rpm

1710(decimal)=06AE(hexadecimal)

D4=06H

D5=AEH

Note 3 : Processing decimal number

Using following methods to process if the minimum parameter value is decimal number.

Minimum unit by 1st decimal number : The original value times 10 to be a new number.

Then,

Use this new number to transfer value into hexadecimal value.

The first two numbers are D5 and the last two numbers are D6.

Ex. Acc. time CD08=60.0 sec

60.0 × 10=600(decimal)=0258(hexadecimal)

D4=02H

D5=58H

The value needs to divide by 10 when it returns to original shape.

Note 4 : Negative number format.

Use two's complement to process negative number.

Ex. Speed command RPM / 0V CD07=-1

Change "-1" to two's complement (FFFFH)

D4=FFH

D5=FFH

(03H, Drive response)

Return to original negative number :

D4=FF>80, the value is a negative number and needs additional format transfer.

FFFFH-01H=FFFEH

FFFEH XOR FFFFH=01H

01H(hexadecimal)=01(decimal), and put it into negative number -1.

(2) 06H : Write parameter setting into drive or address	
Computer command message	
D1 : Communication address	(00~FFh)
D2 : Function code	(06h)
D3 : Parameter number (H)	(00h)
D4 : Parameter number (L)	(0~67h)
D5 : Content of data (H)	(0~FFh)
D6 : Content of data (L)	(0~FFh)
D7 : CRCL or LRC (H)	(0~FFh)
D8 : CRCH or LRC (L)	(0~FFh)
Drive response message	
D1 : Communication address	(00~FFh)
D2 : Function code	(06h)
D3 : Parameter number (H)	(00h)
D4 : Parameter number (L)	(0~67h)
D5 : Content of data (H)	(0~FFh)
D6 : Content of data (L)	(0~FFh)
D7 : CRCL or LRC (H)	(0~FFh)
D8 : CRCH or LRC (L)	(0~FFh)

Ex. Write parameter setting CD04=1500RPM into address 52(34H) driver.

1. RTU

Computer command message :

D1	D2	D3	D4	D5	D6	D7	D8
34H	06H	00H	04H	05H	DCH	CRCL	CRCH

Drive response message :

D1	D2	D3	D4	D5	D6	D7	D8
34H	06H	00H	04H	05H	DCH	CRCL	CRCH

2. ASCII

Computer command message			Drive response message		
	STX	3A		STX	3A
D1	Address '3'	33	D1	Address '3'	33
	Address '4'	34		Address '4'	34
D2	Function '0'	30	D2	Function '0'	30
	Function '6'	36		Function '6'	36
D3	Number of parameter '0'	30	D3	Number of parameter '0'	30
	Number of parameter '0'	30		Number of parameter '0'	30
D4	Number of parameter '0'	30	D4	Number of parameter '0'	30
	Number of parameter '4'	34		Number of parameter '4'	34
D5	CD04 content '0'	30	D5	CD04 content '0'	30
	CD04 content '5'	35		CD04 content '5'	35
D6	CD04 content 'D'	44	D6	CD04 content 'D'	44
	CD04 content 'C'	43		CD04 content 'C'	43
D7	LRC HI	LRC HI	D7	LRC HI	LRC HI
D8	LRC LO	LRC LO	D8	LRC LO	LRC LO
	END HI	0D		END HI	0D
	END LO	0A		END LO	0A

Ex. Computer commands the address 52(34H) driver to operate CW at 1500RPM.

1. RTU

Step 1 : write address 99=1500RPM

Computer command message :

D1	D2	D3	D4	D5	D6	D7	D8
34H	06H	00H	63H	05H	DCH	CRCL	CRCH

Drive response message :

D1	D2	D3	D4	D5	D6	D7	D8
34H	06H	00H	63H	05H	DCH	CRCL	CRCH

Note : Process step 2 directly if address 99 is set in 1500RPM already.

Step 2 : write address 100=1

Computer command message :

D1	D2	D3	D4	D5	D6	D7	D8
34H	06H	00H	64H	00H	01H	CRCL	CRCH

Drive response message :

D1	D2	D3	D4	D5	D6	D7	D8
34H	06H	00H	64H	00H	01H	CRCL	CRCH

2. ASCII

Step 1 : write address 99=1500RPM

Computer command message			Drive response message		
	STX	3A		STX	3A
D1	Address '3'	33	D1	Address '3'	33
	Address '4'	34		Address '4'	34
D2	Function '0'	30	D2	Function '0'	30
	Function '6'	36		Function '6'	36
D3	Number of parameter '0'	30	D3	Number of parameter '0'	30
	Number of parameter '0'	30		Number of parameter '0'	30
D4	Number of parameter '6'	36	D4	Number of parameter '6'	36
	Number of parameter '3'	33		Number of parameter '3'	33
D5	CD30 content '0'	30	D5	CD30 content '0'	30
	CD30 content '5'	35		CD30 content '5'	35
D6	CD30 content 'D'	44	D6	CD30 content 'D'	44
	CD30 content 'C'	43		CD30 content 'C'	43
D7	LRC HI	LRC HI	D7	LRC HI	LRC HI
D8	LRC LO	LRC LO	D8	LRC LO	LRC LO
	END HI	0D		END HI	0D
	END LO	0A		END LO	0A

Step 2 : write address 100=1

Computer command message			Inverter response message		
	STX	3A		STX	3A
D1	Address '3'	33	D1	Address '3'	33
	Address '4'	34		Address '4'	34
D2	Function '0'	30	D2	Function '0'	30
	Function '6'	36		Function '6'	36
D3	Content of data '0'	30	D3	Content of data '0'	30
	Content of data '0'	30		Content of data '0'	30
D4	Content of data '6'	36	D4	Content of data '6'	36
	Content of data '4'	34		Content of data '4'	34
D5	CD31 content '0'	30	D5	CD31 content '0'	30
	CD31 content '0'	30		CD31 content '0'	30
D6	CD31 content '0'	30	D6	CD31 content '0'	30
	CD31 content '1'	31		CD31 content '1'	31
D7	LRC HI	LRC HI	D7	LRC HI	LRC HI
D8	LRC LO	LRC LO	D8	LRC LO	LRC LO
	END HI	0D		END HI	0D
	END LO	0A		END LO	0A

(3) 08H : Communication loop detection		
Computer command message		
D1 : Communication address		(0~FFh)
D2 : Function code		(08h)
D3 : Data 1		(0~FFh)
D4 : Data 2		(0~FFh)
D5 : Data 3		(0~FFh)
D6 : Data 4		(0~FFh)
D7 : CRCL or LRC (H)		(0~FFh)
D8 : CRCH or LRC (L)		(0~FFh)
Drive response message		
D1 : Communication address		(0~FFh)
D2 : Function code		(08h)
D3 : Data 1		(0~FFh)
D4 : Data 2		(0~FFh)
D5 : Data 3		(0~FFh)
D6 : Data 4		(0~FFh)
D7 : CRCL or LRC (H)		(0~FFh)
D8 : CRCH or LRC (L)		(0~FFh)

Drive response messages need to be same as command message when do communication loop detection.

Ex. Computer commands the address 52(34H) driver, data1=11, data2=22, data3=33, data4=44

1. RTU

Computer command message			Drive response message		
D1	Address	34H	D1	Address	34H
D2	Function code	08H	D2	Function code	08H
D3	Data 1	11H	D3	Data 1	11H
D4	Data 2	22H	D4	Data 2	22H
D5	Data 3	33H	D5	Data 3	33H
D6	Data 4	44H	D6	Data 4	44H
D7	CRCL	CRCL	D7	CRCL	CRCL
D8	CRCH	CRCH	D8	CRCH	CRCH

2. ASCII

Computer command message			Drive response message		
	STX	3A		STX	3A
D1	Address '3'	33	D1	Address '3'	33
	Address '4'	34		Address '4'	34
D2	Function '0'	30	D2	Function '0'	30
	Function '8'	38		Function '8'	38
D3	Content1 '1'	31	D3	Content1 '1'	31
	Content1 '1'	31		Content1 '1'	31
D4	Content2 '2'	32	D4	Content2 '2'	32
	Content2 '2'	32		Content2 '2'	32
D5	Content3 '3'	33	D5	Content3 '3'	33
	Content3 '3'	33		Content3 '3'	33
D6	Content4 '4'	34	D6	Content4 '4'	34
	Content4 '4'	34		Content4 '4'	34
D7	LRC HI	LRC HI	D7	LRC HI	LRC HI
D8	LRC LO	LRC LO	D8	LRC LO	LRC LO
	END HI	0D		END HI	0D
	END LO	0A		END LO	0A

E. Communication error drive respond

Once communication error happend, drive will respond “Function code and 80H” and communication error code to master system.

Communication error code definition

Error code	Description
01H	Function code error only (03/06/08 available)
02H	Illegal data address(data address is not available)
03H	Illegal data value(data value is outside limit value)
04H	Illegal command, drive can't do this command
05H	Check sum error

Once communication error happened, drive respond as follow

1.RTU

D1	D2	D3	D4	D5
Address	Function code & 80H	Error code	CRCL	CRCH

2.ASCII

STX	3A
Address (01)	30
	31
Function code & 80H	38
	36
Error code (02)	30
	32
LRC (77)	37
	37
End code H	0D
End code L	0A

EX. In drive 01 write 1B58(7000rpm) to parameter address 04,
but CD04 upper limit is 6000rpm (1770H).

1.RTU

Computer command message :

D1	D2	D3	D4	D5	D6	D7	D8
01H	06H	00H	04H	C3H	50H	CRCL	CRCH

Drive response message :

D1	D2	D3	D4	D5
01H	86H	02H	CRCL(C3H)	CRCH(A1H)

2.ASCII

Computer command message		Drive response message	
STX	3A	STX	3A
Address '0' Address '1'	30	Address '0' Address '1'	30
	31		31
Function '0' Function '6'	30	Function '8' Function '6'	38
	36		36
Address content '0' Address content '0' Address content '0' Address content '4'	30	Error code '0' Error code '2'	30
	30		32
	30	LRC HI '7' LRC LO '7'	37
	34		37
CD04 content '1' CD04 content 'B' CD04 content '5' CD04 content '8'	31	END HI	0D
	42	END LO	0A
	35		
	38		
LRC HI	LRC HI		
LRC LO	LRC LO		
END HI	0D		
END LO	0A		

Communication loss time detect
CD25

Setting Range	0.1 ~ 100.0SEC
Default value	0.5SEC

When communication loss time over CD25 setting, BL2 will active as CD26 selected.

Communication loss
CD26

Setting Range	0 ~ 3
Default value	3

0 : Alarm and keep operation.

1 : Alarm and decelerate to stop.

2 : Alarm and free to stop.

3 : No alarm and keep operation.

Note : Warning means Fault Relay active.

Communication error detect
CD27

Setting Range	1 ~ 10
Default value	3

When communication error continuous time more than CD27 setting. BL2 will active as CD27 selected.

Note : Two method to clear communication loss or error.

One is pressing key, the other is setting address 100=0

1st speed in digital
CD28

Setting Range	0 ~ 6000RPM / 0 ~ 15000RPM
Default value	1000RPM

L : 0~2000RPM.

M : 0~3000RPM.

H : 0~6000RPM.

HX : 0~15000RPM.

Note : This parameter does not work in open loop control.

2nd speed in digital
CD29

Setting Range	0 ~ 6000RPM / 0 ~ 15000RPM
Default value	2000RPM

L : 0~2000RPM.

M : 0~3000RPM.

H : 0~6000RPM.

HX : 0~15000RPM.

Note : This parameter does not work in open loop control.

Reset to default
CD30

Setting Range	0 or 1
Default value	0

Set address CD30=1 to reset parameters to be in default values. This parameter value will be back to 0 after reset command automatically.

Communication address description

RS485 speed command
99

Setting Range	0 ~ 6000RPM / 0 ~ 15000RPM
Default value	0RPM

Write speed command to address 99 in RS485 mode.

RS485 operating command
100

Setting Range	0 ~ 3
----------------------	--------------

- 0 : Clear communication loss and communication error fault relay.
- 1 : CW.
- 2 : CCW.
- 3 : Stop.

Note : This is last operating command value and it is not real motor running condition.

Motor speed (RPM)
101

This parameter is real motor speed value. Use RS485 protocol 03H to read motor speed.

Motor running condition
102

This real motor running condition.

0 : No define

1 : CW

2 : CCW

3 : Stop

Error code
103

Use RS485 protocol 03H to read error code if driver is in protection mode.

1 : Hardware fault or EEPROM error.

2 : Motor overheat.

3 : Driver over current, over voltage or over heat.

4 : Driver over load.

5 : Over speed.

6 : Speed too low.

7 : Mod Bus fail.

8 : Motor lock protection.

9 : Hall sensor fail.

9. Trouble shooting

Motors free run to stop when protect functions are effected.

Disconnect power to reset the protect function.

For safety , make sure all problems are solved before reconnect power.

To wait more than 5 minutes to reconnect power after disconnect power.

Display symbol	Description	Check point and suggestion
Err1	EEPROM error	Press  to reset alarm and set CD30=1, to reload default value to EEPROM.
Err2	Motor overheat	Check motors cooling condition. Check motors loading, motors may be overload.
Err3	Over current	Check input voltage(over voltage). Check drives cooling condition (overheat). Check motors loading (overload). Check wire & plug between motors and drives (U,V,W shortage). Check Acc. & Dec. time setting (over current). Check CW, CCW, stop operation frequency (over current). Check inertial load, motors may get traction from loading.
Err4	Over load	Check connector if it is bad connection. Wait 5 min to restart motor.
Err5	Over speed	Check loading variation if load reduces too fast.
Err6	Speed to low	Check loading variation if load increases to fast.
Err8	Motor lock protection	Check rotor lock. Check load condition.
Err9	Hall sensor fail	Check wire & plug between motors and drives.
	Mod Bus fail	Check all drives setting are accordance. (address, communication speed, data format) Check communication wires are A to A and B to B.

Appendix

1. External braking resistor

Dimension

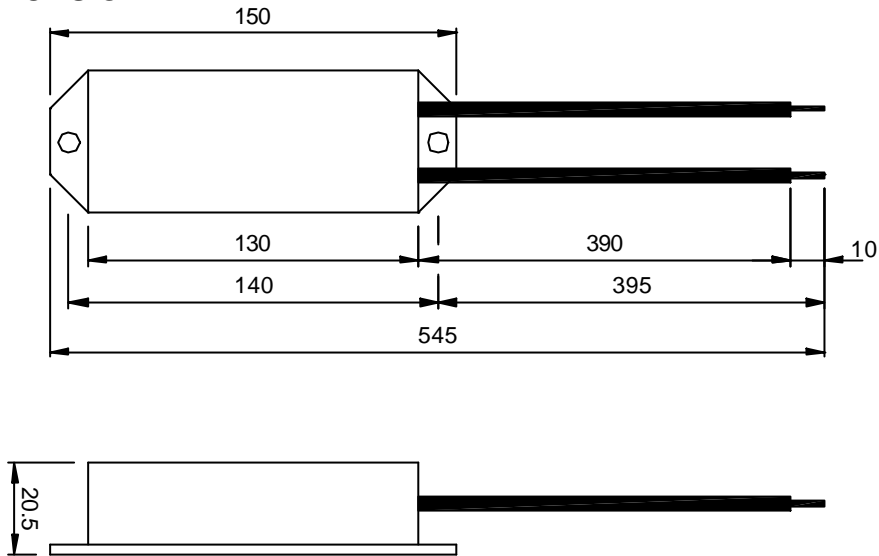

Part No. : E-MSAA-008000

Specification : 60 80W

The resistor value is recommended as below. The value must be higher than list value.

Unit :

Model No.	01	02	04	07	15	22
BL2	60	60	60	60	60	60

Evaluation of braking resistor watt

Model	Resistor watt
AM-750~2200(H) CM-750~2200(H)	$(1330/T) \times (W/6000)^2$
AM-750~2200(M) CM-750~2200(L)	$(436/T) \times (W/3000)^2$
AM-60~370(L/M/H)	$(220/T) \times (W/6000)^2$

P : Watt
T : Deceleration time
W : Motor speed
The above calculation loading are based on 5 times rotor inertia

2. Hall sensor and F306 remote operator extension cable

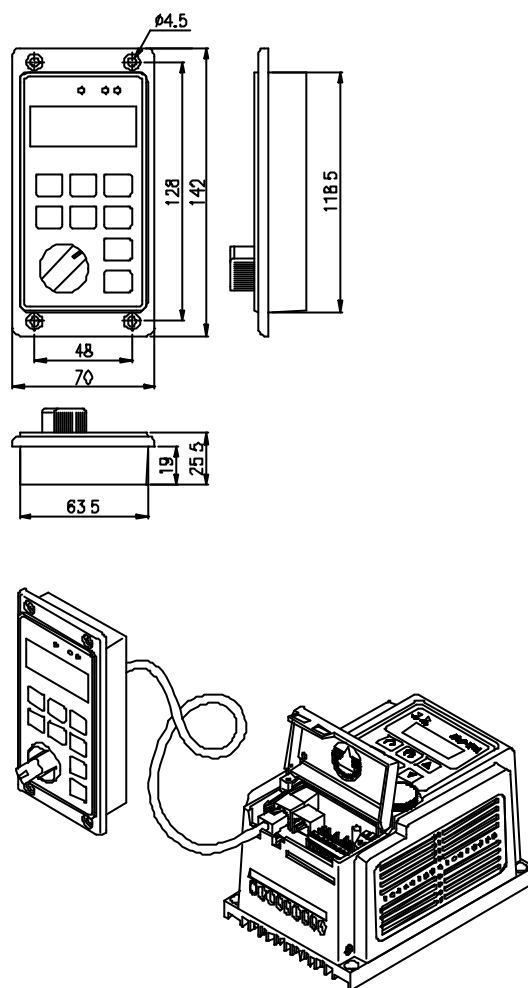

A-0000-F306G3	F306 Remote operator
E-092A-010200	1 meter extension cable
E-092A-030200	3 meter extension cable
E-092A-050200	5 meter extension cable
E-PEAA-8P8C02	Extension connector

INSTRUCTION MANUAL

PART NO : E-PHAA-EBLA02

Model : BL2 series

JUL. 2008 3st edition



ADLEEPPOWER[®] SERVICE OFFICE

FREQUENCY INVERTER MOTOR DRIVES

Taiwan

Tel No : 886-4-25622651

Fax No : 886-4-25628289

E-mail : webmaster@adlee.com

URL : <http://www.adlee.com>

Hong Kong

Tel No : 852-24081937

Fax No : 852-24071036

Guang Dong (China)

Tel No : 86-757-26656498

Fax No : 86-757-26658515

Wu Han (China)

Tel No : 86-27-59322991

Fax No : 86-27-59322992

Shanghai (China)

Tel No : 86-21-64843529

Fax No : 86-21-64837594